

THE INTERLOCK
REIMAGINED.

XDI™ SERIES DOOR INTERLOCK SWITCH

Peace of mind within reach. With the X Tronics XDI™ Series , improve speed and efficiency while eliminating costs and safety concerns.

A combination of performance and safety, the X Tronics XDI™ Series Door Interlock Switch is an electromechanical device designed to provide peace of mind when operating accessibility equipment by securing the landing or elevator door in place, preventing it from being opened in potentially unsafe conditions.

It's **industry-leading** design adapts to various applications including swing or sliding doors, dumbwaiters, material lifts, lifts for mobility impaired and private residence swing-door elevators.

PERFORMANCE SPECIFICATIONS

Service Life	10 years
Operating Temperature	-40°C to 38°C (-40°F TO 100.4°C) Sealing: IP67 Sealed (with silicon boot)
Storage Temperature	-40°C to 60°C (-40°C TO 140°F)
Approval	Listing No. E10695  
Electrical Rating	1.5A MAX., 27VDC MAX
Electrical Contacts	Long life (1,500,000 endurance cycles), Silver (Ag/AgSnO2), Positive Openings, Snap-action., Self-cleaning.

FEATURES

ASME A17.1, ASME A18.1, CSA B44, and CSA B355 compliant
Two separate mechanical actions to indicate door closure
No maintenance
Metal key engagement
Door closure retention cam to hold door with minimal key-to-interlock play
Exceeds commercial pull force standard of 675 pounds
Runway and landing key override for easy actuation without user hazard and code compliance
Plug-in wire terminal available
24VDC applications - Continuous 100% duty cycle rated solenoid, 10W power consumption
12.00 in W x 8.50 in H x 1.75 in D
Available silicon boot for outdoor use

FEATURES

As opposed to traditional door and gate latches, the XDI™ helps protect personnel and equipment by preventing operation of drive mechanism unless the door is locked and closed. Further more, it prevents the landing door from opening until the cab is within the door zone.

When the cabin has reached the desired landing, upon de-energizing (unlocking) the solenoid, the XDI™ automatically releases the door or gate, allowing safe exit.

- Increased security and peace of mind for personnel and cargo
- Meets required safety codes
- Reliable performance and multiple design features to minimize nuisance stoppage

KEY BENEFITS

INNOVATIVE INDUSTRIAL DESIGN

- A modern design resulting from intensive usability research and analysis.
- Reduces OEM design and manufacturing costs.
- Fully machined and hardened aircraft aluminum/magnesium alloy casing for a robust and high-quality finish.
- High-contrast black finish and square shape that blends seamlessly with a wide variety of new and existing architectural designs.

GREATER EFFICIENCY

- Reliable performance and multiple design features minimize nuisance stoppage.
- Simplified wiring and installation process.

SEAMLESS INTEGRATION

- The XDI™ can be integrated into wide variety of current designs including; Swing and Sliding Doors, Dumbwaiters, Material Lifts, Mobility and Accessibility Lifts, Private Residence Elevators, and more.



Balanced Approach
The XDI™ provides the perfect blend of design and practical features.

Seamless Integration
The XDI™ can be integrated into wide variety of current designs.

XDI™ Series Interlocks are available with a wide selection of configurations including left and right hand designs, allowing for simple installation, customization, and even retrofitting into current designs and projects.

The XDI™ design contributes to increased safety, reducing nuisance stoppages and service calls.

CATALOG NUMBER

Example: XDI - L S 5

XDI
XDI™ Series

Interlock configuration

L Left-hand Interlock 

R Right-hand Interlock 

WIRING

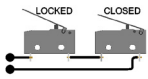
S Switch in series 

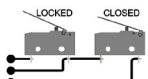
P Switch in parallel 

RUNWAY UNLOCK

1 No runway unlock

2 Miniature barrel key 

3 Miniature flush screw 

4 Unlocking screw for flat blade Ø 1/2" 

5 Unlocking thumb screw Ø 3/4" 

OPTIONAL PARTS

XDI-BOOT	Silicon boot for outdoor use
XDI-001-02	Replacement Engagement key
XDI-002-25	Replacement Aluminum XDI™ cover
XDI-002-26	Replacement Aluminum lock cap with Ø 1/16" dowel pins
XDI-002-28	Replacement Aluminum key cap with Ø 1/16" dowel pins
ATP 2025	Elongated Override Key works with XDI™ Series (Options 2 & 5)

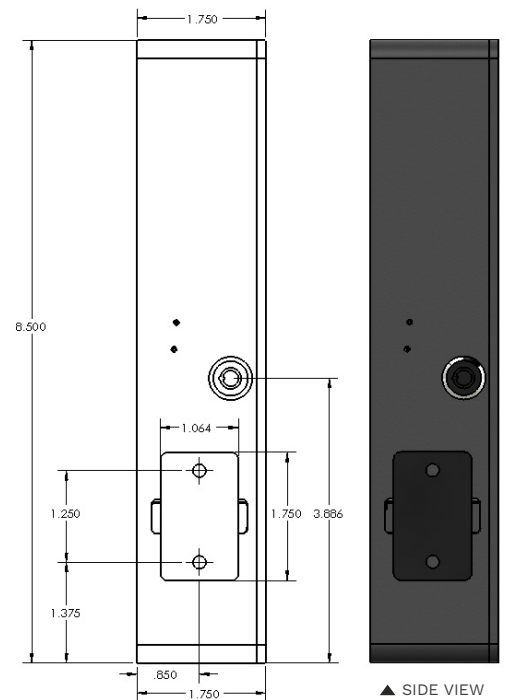
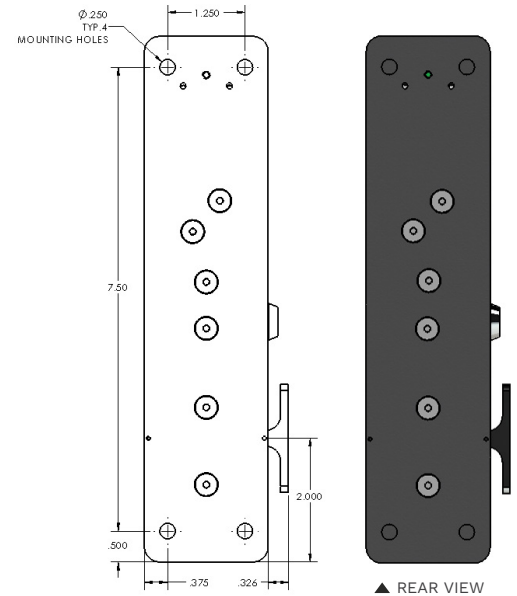
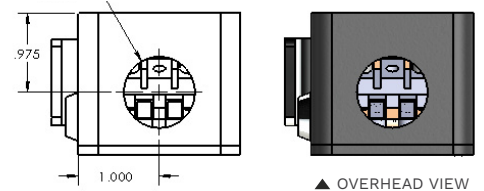

X Tronics Inc. reserves the right to alter the product design and specifications without prior notice. Minor differences between printed and actual products may exist.

Copyright © 2023 X Tronics Inc.